



## HANDRAIL | Bright Line



Refrigeration and Freezer equipment



Handrail lighting



High efficiency



QCS  
Quick-Connection-System



Dimmable



Various lengths

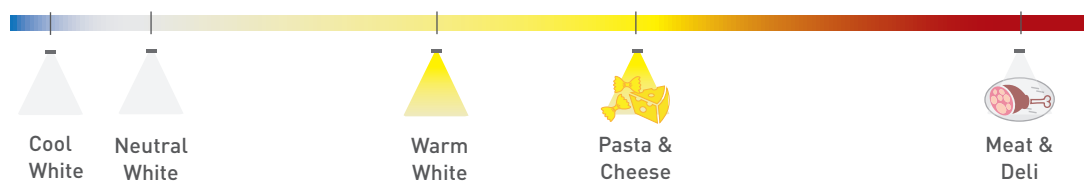

## HANDRAIL | Bright Line

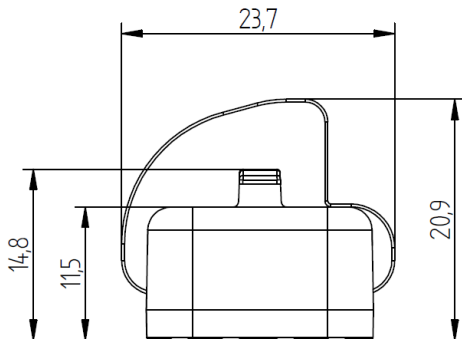

### PRODUCT DESCRIPTION

- High efficient lighting of handrails for cooling and freezer equipment
- Available in a variety of light colours and can be matched to specific food types
- Ready-to-connect solution available, thanks to our Quick Connection System (QCS)
- High operational performance due to directional lighting, integrated heat removal and highly efficient LEDs
- Excellent product illumination thanks to the combination of SMD LEDs and innovative optics
- Safe-use operation due safety extra-low voltage (SELV)
- Simple installation with application of fixing plates
- Heat sink profile made of anodised, extruded aluminium
- LED modules protected against moisture & dust by Conformal coating
- End caps made of PBT
- Linear lenses made of PMMA
- Dimming capability

### TECHNICAL DATA

Supply voltage	24 VDC
Ambient temperature $t_a$	-30 ... +30 °C
Max. surface temperature on profile $t_c$	60 °C
Type of protection	IP20
Protection class	III
Risk group (EN 62471:2008)	1

IP20

### ENERGY CLASS

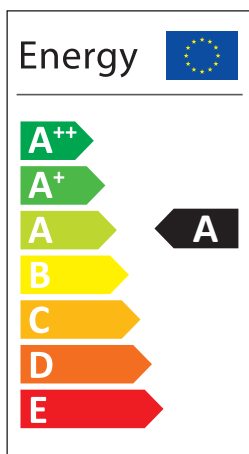

### APPLICATION

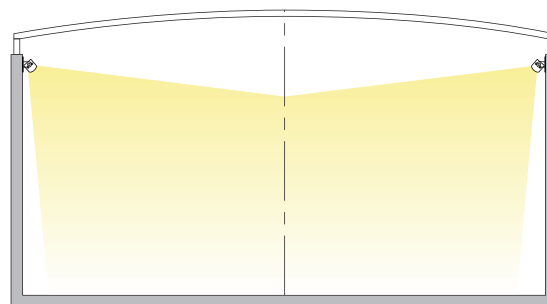

## HANDRAIL | Bright Line

### TECHNICAL DATA | ORDER DATA

Art. Nr.	Type	Colour	No. of modules	Luminous flux (lm)	Power (W)	CRI
91420060	Bright-Line Handrail 630mm, 5000K CRI90, 8W, CLW8Q	CW	4	790	7,6	≥90
91420061	Bright-Line Handrail 630mm, 4000K CRI90, 8W, CLW8Q	NW	4	830	7,6	≥90
91420062	Bright-Line Handrail 630mm, 3000K CRI90, 8W, CLW8Q	WW	4	720	7,6	≥90
91420063	Bright-Line Handrail 630mm, 2700K CRI90, 8W, CLW8Q	PC	4	690	7,6	≥90
91420064	Bright-Line Handrail 630mm, Meat CRI90, 8W, CLW8Q	PM	4	650	7,6	≥90
91420065	Bright-Line Handrail 1200mm, 5000K CRI90, 16W, CLW8Q	CW	8	1580	15,2	≥90
91420066	Bright-Line Handrail 1200mm, 4000K CRI90, 16W, CLW8Q	NW	8	1660	15,2	≥90
91420067	Bright-Line Handrail 1200mm, 3000K CRI90, 16W, CLW8Q	WW	8	1440	15,2	≥90
91420068	Bright-Line Handrail 1200mm, 2700K CRI90, 16W, CLW8Q	PC	8	1370	15,2	≥90
91420069	Bright-Line Handrail 1200mm, Meat CRI90, 16W, CLW8Q	PM	8	1300	15,2	≥90

Packaging: 12 pieces/carton, 360 pieces/pallet

- All typical values for Ta=25°C +/- 2°C, setting time =200ms
- Luminous flux min. value = typ. value - 20%
- Tolerance mechanical dimensions +/- 1mm
- Tolerance electrical data +/- 15%
- Tolerance optical data +/-10%

### CONVERTER

Output voltage	24VDC +10%
Power converter	= sum of the typical individual power of the light engines + 20%
Chain length (luminaires)	120mA: max 21 modules 100mA: max 24 modules 80mA: max 28 modules 60mA: max 33 modules 40mA: max 40 modules

#### Selection of the operating device/protective functions

The operating device protects the modules against overvoltage, overcurrent, overload and short circuits. The device must comply with the relevant standards for safe operation in freezer and refrigeration equipment. Power supply units must ensure the following protective measures:

- SELV
- Short-circuit protection
- Overload protection
- Overtemperature protection
- Protection against environmental influences

### ACCESSORY - MOUNT | FIXING PLATES

Type	METAL 0°	METAL 0° magnetic	METAL 30°	METAL 45°	METAL adjustable	METAL adjustable magnetic
Art. Nr.	88167376	88167382	88167378	88167379	88167384	88167385

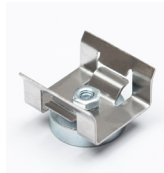

## HANDRAIL | Bright Line

### QUICK-CONNECTION-SYSTEM (QCS) | BRIDGES

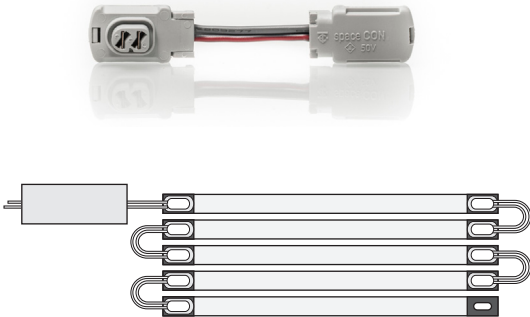

- Bridge for connecting two linear LED engines via QCS
- Bridge for connecting a linear LED engine to a feeder link via QCS

#### ORDER DATA - Bridges

Length	Weight	Type	Art. Nr.
30 mm	0.004 kg	LED Bridge QCS 30 **	89601262
50 mm	0.004 kg	LED Bridge QCS 50 **	89601263
100 mm	0.005 kg	LED Bridge QCS 100 **	89601264
250 mm	0.007 kg	LED Bridge QCS 250 **	89601265
400 mm	0.009 kg	LED Bridge QCS 400 **	89601266
800 mm	0.016 kg	LED Bridge QCS 800 **	89601267
1,200 mm	0.022 kg	LED Bridge QCS 1200 *	89601268
2,000 mm	0.034 kg	LED Bridge QCS 2000 *	89601269

Packaging: \* 25 pieces/carton, 400 pieces/pallet | \*\* 50 pieces/carton, 800 pieces/pallet  
Also available in black.

### QUICK-CONNECTION-SYSTEM (QCS) | FEEDER CABLE



- Feeder cable for connecting a linear LED engine to a converter via QCS

#### ORDER DATA - Feeder Cable

Length	Weight	Type	Art. Nr.
500 mm	0.009 kg	LED Feeder QCS 500 **	89601258
1,000 mm	0.017 kg	LED Feeder QCS 1000 **	89601259
1,500 mm	0.025 kg	LED Feeder QCS 1500 *	89601260
2,000 mm	0.033 kg	LED Feeder QCS 2000 *	89601261
4,000 mm	0.065 kg	LED Feeder QCS 4000 ***	89601601

Packaging: \* 25 pieces/carton, 400 pieces/pallet | \*\* 50 pieces/carton, 800 pieces/pallet | \*\*\* 10 pieces/carton  
Also available in black.

### QUICK-CONNECTION-SYSTEM (QCS) | FEEDER LINK

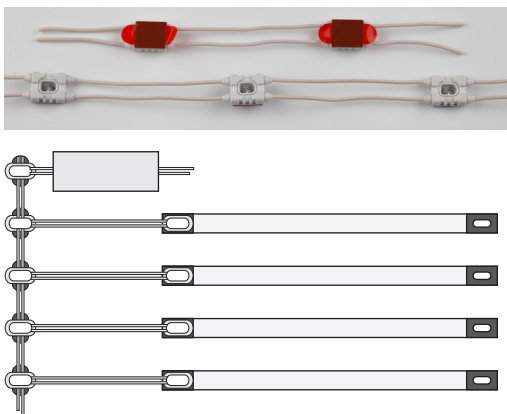

- Flexible feeder link for connecting several linear LED engines to a converter
- Slots equipped with double-sided adhesive tape

#### ORDER DATA - Feeder Link

Length	Spacing	Type	Art. Nr.
10m	108 mm	LED Feeder Link QCS	88711762

Packaging: 1 roll corresponds to 10m with 92 slots

### QCS | PROTECTION SET



- Cover to protect QCS connectors

#### ORDERING DATA - Protection Set

Type	Packaging	Art. Nr.
LED PROTECTION QCS BLIND CAP	1 bag (holds 100 pieces)	88167414
LED PROTECTION QCS END CAP	1 bag (holds 50 pieces)	88167415

## HANDRAIL | Bright Line

### COORDINATES AND TOLERANCES ACCORDING TO CIE 1964 - DATA REFERS ONLY TO LED MODULES WITHOUT COVER

#### Cool White

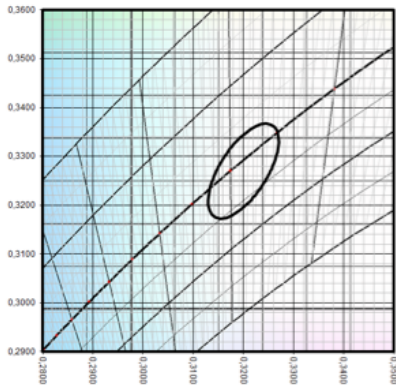

#### CIE coordinates

#### Cool White 4900K

	x0	y0
Centre	0,3478	0,3535
MacAdam Ellipse:	3SDCM	

Suitable, e.g., for frozen products and fish

#### Pasta & Cheese

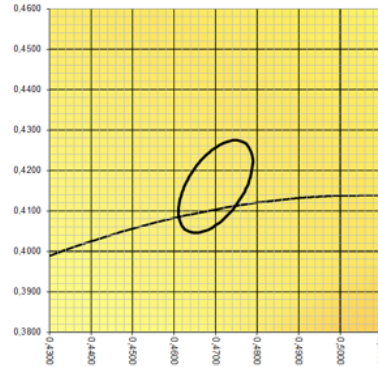

#### CIE coordinates

#### Pasta & Cheese 2660K

	x0	y0
Centre	0,4750	0,4160
MacAdam Ellipse:	3SDCM	

Special colour for pasta & cheese

#### Neutral White

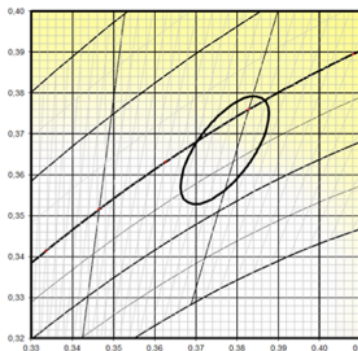

#### CIE coordinates

#### Neutral White 3950K

	x0	y0
Centre	0,3770	0,3660
MacAdam Ellipse:	3SDCM	

Suitable, e.g., for dairy products and frozen products

#### Meat & Deli

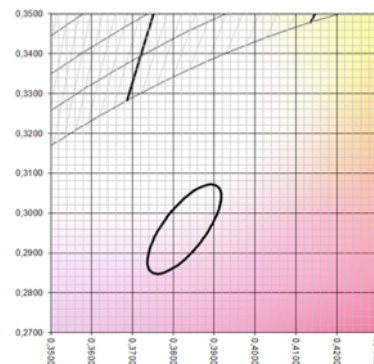

#### CIE coordinates

#### Meat & Deli

	x0	y0
Centre	0,3830	0,3060
MacAdam Ellipse:	3SDCM	

Special colour for meat and deli

#### Warm White



#### CIE coordinates

#### Warm White 2800K

	x0	y0
Centre	0,4480	0,3990
MacAdam Ellipse:	3SDCM	

Suitable, e.g., for vegetables, fruit and wine

## HANDRAIL | Bright Line

### COLOUR KEY

Code	CW	NW	WW	PC	BP	PM
Colour	Cool White	Neutral White	Warm White	Pasta & Cheese	Bread & Pastries	Meat & Deli
CCT	5000K	4000K	3000K	2700K	2400K	special colour

### LIFETIME

50.000h (L70 B10)

### THERMAL BEHAVIOUR

Operating temperature (operation, no defects)	ta	-30 ... +30 °C
Storage temperature	ts	-30 ... +60 °C
Temperature cooling profile <sup>12</sup>	tc	-30 ... +60 °C

<sup>1</sup> Values apply to operation at 100% output, natural convection.

<sup>2</sup> If the maximum temperature limits are exceeded, the lifetime of the module will be greatly reduced or the module may be destroyed. The tc point temperature at the profile of the light engine should be measured in the thermally stable state and under operating conditions by means of a temperature sensor or temperature-sensitive sticker (available for example from conrad.com or rs-components.com) in accordance with EN60598-1. The entire profile can be used as the tc point.

### STANDARDS

- EN 60598-1
- EN 60598-2-1
- EN 62031
- EN 62471
- EN 60335-2-89 ANNEX BB



#### Note

- Installation should only be conducted by a licensed electrician.
- Reversing the polarity can damage the product!
- Make sure the converter has been switched off prior to connecting the light engine. If this is not observed, the light engine may be damaged!
- Connection or operation is only permitted when using the specified converters. Higher voltages result in damage to or failure of the light engine.
- The user is responsible for correct selection of illumination intensity. Excessive illumination intensity may lead to greying or colour changes of displayed products.