

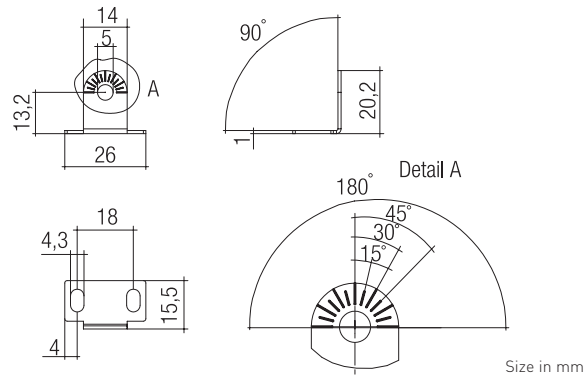

MOUNT | BRACKET

MOUNT | BRACKET

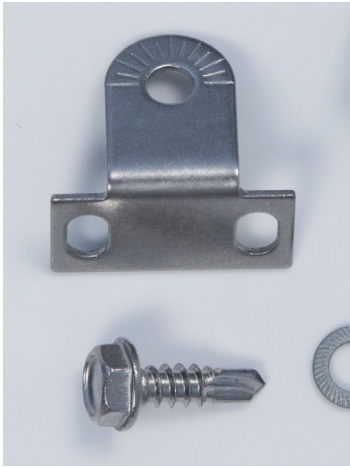

PRODUCT DESCRIPTION

- Mounting bracket with locking screw (hexagon screw ST4.8 x 16 incl. locking washer) for optimum alignment of linear engines
- Angle marking for precise alignment
- Minimum space needed for mounting
- Metric M4 screws or ST4.2 self-tapping screws are needed for fixing the mounting bracket (not included)
- Made from steel 1,4301
- Frosted grey

TECHNICAL DATA

Dimensions L x W x H	26 x 15.5 x 20.2 mm
Weight	0.07 kg

RoHS

ORDERING DATA - MOUNT | Bracket

Type	Art. Nr.
LED MOUNTING BRACKET for profile Z22W - adjustable	24166024

2 pieces are needed for fixing the linear engine. 100 pieces/carton